

How to Set Up Community Libraries For Children



Prepared by: Osu Children's Library Fund

The Joy of Reading

Every time we open a book, we discover something new – a beautiful story or a fairy-tale, the strange and wonderful habits of animals, the mysterious world of science, and the customs of people who live in a far-distant country. And every time we open a book, we learn something new – we learn numbers and letters, colours and shapes, poetry and songs. Books are, quite simply, windows on the world! A library is a place to read and to enjoy and celebrate books.

What is a children's library?

A children's library is a place where there are books, children and committed and enthusiastic staff to assist the children to develop their reading skills. Libraries depend on financial and staffing resources and come in a variety of styles.

Adult libraries and children's libraries, what is the difference?

When adults come to a library, they usually know how to read and they are seeking information on a specific topic, or a certain kind of fiction book to read. Adults will usually seek out staff and ask for assistance. If adults cannot read and if they are interested, they can be directed to adult literacy classes in their community.

Young children may not be able to read so they need to be attracted to the library and, whenever possible, assisted with their reading skills. Children need to feel comfortable in a library setting and should be gently encouraged to participate in the activities offered. The staff should play an interactive role with the children. It is a very demanding job, but also a very rewarding one.

Part One: Active Programming

“Few children learn to love books by themselves. Someone has to lure them into the wonderful world of the written word; someone has to show them the way.”...Orville Prescott from “A Parent Reads to his Children”

The role of librarians cannot be more important for creating a nation of readers. Providing opportunities for children to read helps a great deal, but a library has the potential to offer so much more. For a child who is unable to read, active participation on the part of the librarian can play a major role and should be encouraged.

Story times

Story times should be considered part of a daily library routine. By reading aloud from books or telling stories, librarians can build up the vocabulary of library members and improve their listening, comprehension and observational skills. Good listening skills provide a foundation for reading later on and are, therefore, very important. If a child has never heard a particular word before it is unlikely that the same word in print will have any meaning. Many children come from homes where their parents are not able to read stories to their children; either they don't have the literacy skills or there isn't time. A library can play an important role here.

Story times may include the following activities:

1) Telling a story in English or in one of the local languages

2) Reading a story

First introduce the story by giving the title, author and illustrator and set the stage by telling a little of what the story is about. For example, in the story of Cinderella, you could explain that it is about a young girl who lives with her stepmother and two mean stepsisters. Hold the book so that the children can see the illustrations.

Asking questions and leading a discussion of the story, thereby testing their understanding of the plot, the kind of characters, where the story takes place, etc.

3) Performing finger plays and singing action songs

4) Hearing and reciting poetry and nursery rhymes

5) Providing opportunities for quiz competitions

The types of activities will depend on the age and needs of the library members. There should also be opportunities for library members to take turns reading stories aloud. This will promote confidence in their ability to read and will encourage others to do so.

During a recent study, a Primary Five student achieved an exceptionally high reading score. When questioned she explained that she didn't have a book at home, but visited the library every day after school to listen to stories and read. Daily story times play an important role at her library.

Puzzles and games

If there are funds in the budget, the purchase of puzzles and quiet games for in-library use add a great deal. Children certainly enjoy the challenge of completing puzzles; puzzles help with motor coordination, memory skills and understanding spatial relationships. Games also encourage cooperation among others and promote social skills. Careful attention to keeping the educational materials intact needs to be given as a puzzle or game with a missing piece is not much fun! At busy libraries we arrange for children to sign out their puzzles or games in an exercise book. It is required that they be returned intact to their original spot.

A small library in Accra takes great pride in their wooden, locally made jigsaw puzzles. The puzzles are used daily and, after 10 years, most of them are still intact!

Drama

Libraries are wonderful places where drama can be enjoyed. Stories, both from books and the imagination, can be acted out for other library members. Simple costumes and props add a great deal to the performance.

Guest speakers

Libraries offer countless opportunities to engage others from the community to share information. This can be in the form of talking about careers, news items and health issues.

At a children's library in Accra serving a poor, densely populated area, a doctor was invited to speak about abortions, a topic suggested by a library member. The questions asked by the teenage members of the library were well thought out and served an invaluable purpose.

Miscellaneous activities

There are no limits to the sorts of activities that can be offered through libraries. The types of programs depend on the resources available and the talents and interests of library staff.

A large library in Accra promotes free twice-weekly literacy classes, a wildlife club, a choir, two football teams and puts together a newsletter highlighting members' contributions. Although the range of programs seems beyond the typical library definition, books and literacy are still the essential component. One of the football teams is called the "Joy of Reading"!

Part Two: How to Maintain and Operate a Children's Library

According to the dictionary, a library is defined as, "a room or building where a collection of books is kept". A library can really be any size. It can simply be an area under the shade of a tree where children gather on mats, or a small room in a house, a school or a community centre. A library can also be a larger freestanding building accommodating hundreds of children. The size doesn't really matter. The enthusiasm and commitment of the staff members make the difference!

Whatever the library size, funds need to be spent wisely. The following is a breakdown of expenses excluding the costs associated with the library space:

Library staff

A library's success is wholly dependant on its staff members who, while working together, derive pleasure from their work and, more importantly, like interacting with children. It is important that the staff members work cooperatively; their roles need to blend in harmony in order for the numerous tasks of the library to be accomplished. Everyone should be encouraged to take ownership for having an organized, well-attended and attractive library and surrounding compound.

It is crucial that the library have at least one paid staff member (funded by the community, either privately or with government support) who will take the responsibility of running the library. This person will not only need to be in command of the day-to-day running of the library but will need to have a gentle, yet, firm character to manage the large number of children who pass through the library's doors every day. In addition to paid staff, teachers and community volunteers make a valuable contribution.

Regular staff meetings are important to discuss new ideas and bring up areas of concern. Unfortunately, salaries of library staff members tend to be quite low and this is often an issue.

If the library is at school it is helpful to have library prefects or 'monitors' assisting the one overseeing the library's operation. The students should be selected from two different years to allow for continuity. Monitors are then given the responsibilities of daily cleaning, preparing the books in an orderly fashion and demonstrating book care.

Books

There is always a temptation to gather as many books as possible for a library. It is much better, however, to have a good selection of well-written and colourful books that you think the children might enjoy versus large numbers of inappropriate, drab-looking books. Keep all the books in good order and dust and clean them on a regular basis. Glossy-covered books can be wiped with a slightly damp cloth (with a small bit of diluted soap) and dried.

If the books are soft cover without a laminated finish they should be protected with a clear plastic cover. We purchase large clear bags (the ones used by the market women for selling quantities of food items) and cut them to the required book size. The plastic is held in place with clear tape. Another option is to order plastic sheeting in bulk from a plastic factory. They will make it according to the width and thickness required.

An inventory list should be kept of all books received. **If your budget is limited the books should be kept at the library and not loaned out, as it is very costly to replace books.** It is unlikely that an African child will have the financial means to replace a missing or damaged book.

We visited a new community library (serving both adults and children) in rural Ghana and we were surprised to see thousands of books lining the library's bookshelves BUT not a single storybook seemed appropriate for an early reader.

Where to keep books?

If funds are scarce, and, if the library is small, books could be kept in durable bags or lightweight metal boxes and brought out for library use.

For larger, permanent libraries, books should be placed on bookshelves with their spines facing out allowing the children an opportunity to read the titles easily. When making shelves, think of the types of books they will accommodate, as the shelf heights need to be appropriate. It is best if the top shelf is not too high; this is both to make dusting effortless and to give children easy access to the books. The surface of the top shelf may be used to feature newly acquired books. A library looks much better if there are not too many empty shelves; low bookshelves do not require as many books. Display racks can also be made with sloping shelves so books or magazines can be displayed individually.

For young children the best way to display books is using kinderboxes, wooden cabinets that stand slightly off the floor (they are divided into four sections and each section can accommodate approximately 25 books).

Whatever furniture is built try to have it well made with carefully sanded surfaces and nicely polished. Bookshelves that are not completely smooth will damage the books as they are taken off the shelves. Occasionally, the furniture should be checked for insect infestation; if that happens the affected wood should be removed immediately.

Sadly, many libraries make the mistake of investing large sums of money on bookshelves

that line the walls. Their modest book collections tend to look insignificant in comparison to what their bookshelves can accommodate – very discouraging for all.

Other furniture

If the library is in a temporary structure mats can be used for the children to sit on and a stool or chair for the librarian.

For a permanent facility the furniture should include a desk for the librarian, small tables, chairs or stools for the children and mats for story time. If furniture is too big, a child will most likely feel awkward and/or inadequate. This can affect how they feel about themselves and their confidence or lack of confidence in their ability to read or attempt new tasks. If literacy classes are being held for adults, larger tables and chairs should be included.

Additional materials

Every library, large or small, should have a washbasin with soap and towels for children to wash and dry their hands before entering the library. Ideally, there should be two: one for washing and one for rinsing (please see diagram below).

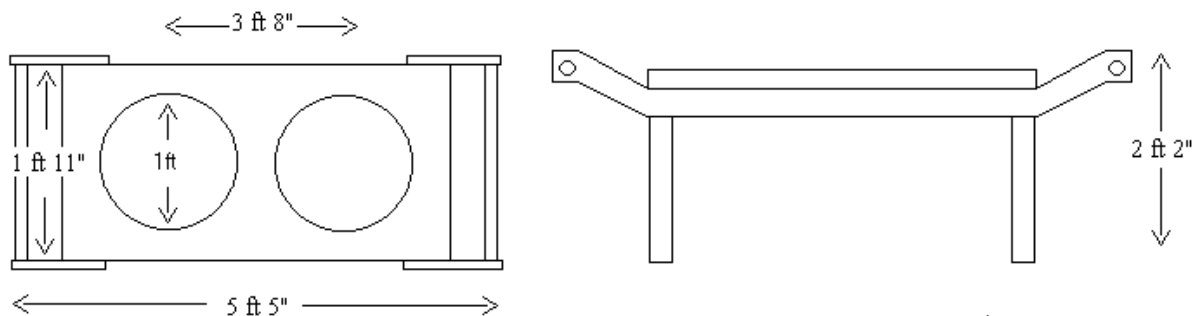

Figure 1.0

Note: Hand towels can be placed at the side of the wooden frame. Clothes pegs (joining the two sides together) can be used to keep the towels from falling off.

Books are very expensive and children (and adults!) should learn early on that books require proper care. In addition to clean hands, those reading will need to be shown how to turn the pages carefully so that they don't tear. Books will last for many years if they are treated with respect. If care is not taken, books will only last a few days before being torn and soiled.

Lighting

It is important to ensure that the lighting is adequate, either ample natural daylight or good overhead electric lighting. Good natural lighting is far superior to overhead lighting for reading. Walls that are painted in white or light colours are more suited to libraries because they reflect light. Note: For ease of cleaning we recommend using a high-gloss paint for the first five feet from the floor

Ventilation

If the library is to be accommodated in a room or building, careful attention should be paid to ventilation. When air does not circulate properly, a room can easily become hot, humid and stuffy. These are conditions that make reading and learning very difficult.

Library hours

It is necessary to assess the needs of the potential library members prior to setting out the library's hours of operation. Staff should arrive punctually and welcome the children according to the posted hours of operation. If the library is closed, notification should be posted. Regular activities including story times should also be carried out punctually. Otherwise the children will lose interest.

A beautiful library

Attention to keeping the library clean cannot be overemphasized. Cleaning and dusting

the books and furniture, and sweeping and damp-mopping the floors daily take a great deal of time. The operating hours of the library should provide sufficient time for this.

Libraries should be cheerful, bright and welcoming places. Visiting the library is not a required activity and, therefore, it is important to make the place as inviting as possible. Colourful wall hangings help, as do photos, banners and children's drawings or creative writing pieces. Changing the displays is advisable and, over time, it is good to highlight work from all participating library members. Every child likes to see his or her piece displayed!

Flowers and bushes planted outside add colour and make libraries attractive places to visit. A dustbin near the entrance will keep the place neat and will discourage littering.

Young library members were asked to draw pictures of their library and they exhibited them proudly on the notice board. Their pictures showed the library decorated with colourful flowers, curtains neatly pulled back and lots of smiling faces.

Respect for the library

Children should feel a sense of pride in their library and treat the room and its contents as property belonging to their community. This means that children should refrain from sitting on the tables, writing on the furniture or books, and keeping hands from the wall (soiled walls look unsightly).

"Don't touch the wall!" is probably repeated 20 times per day, in many cases by young regular members, at a busy library in Accra.

Although the library can be a lively place with quiet discussions among children and, possibly, singing at story times, shouting should not be permitted. If children are shouting

or acting aggressively they should be quickly escorted out of the library and told to return another day. Food should be kept outside the library and chewing gum discouraged.

Evaluation of a library's performance

It is important to have a guest book for comments and suggestions. A written record of the library's performance also allows one to assess the library's development and progress on a monthly and annual basis. The statistical records should detail the daily attendance of all library visitors, indicate special programs offered and note concerns. Information regarding expenses could be included to provide an easy reference for annual expenses.

Costs Involved in running a library

The costs of setting up a library are completely dependent on the setting and size of the library. The initial expenses to set up a library are significant and there is often a big rush to raise funds for books and bookshelves. Sadly, very little consideration is given to planning for the month-to-month payments of the staff salaries and library upkeep. A library's success, however, relies on excellent staff and this falls apart quickly if money cannot be found for salaries. The community or school supporting the library should be involved in addressing these issues from the very beginning.

Many libraries think that they can generate ongoing funding from membership fees and user charges. **Please think twice about doing so because it denies children from impoverished homes the opportunity to visit the library.** On the other hand, there can

be two levels of privileges: one where the member pays a fee for borrowing or one where in-library reading and library activities are free.

Conclusion

With careful planning and community support a library is a wonderful resource for children and their parents. Please keep in mind that a few good books and an enthusiastic librarian under the shade of a tree do more to foster reading than a big library with thousands of tattered and inappropriate books and uninterested staff.

NB Please feel free to copy these guidelines.

Comments and suggestions should be sent to this address: kknowles@mts.net

Our website address is: www.osuchildrenslibraryfund.ca